

A History of BetaJet



Beta

Why we designed BetaJet and BetaStation

- In the 1990's, we were selling a large competitor's proportioners in Europe
- Our customers experienced a number of field problems, resulting in high trouble call costs
- Our UK engineers spent a great deal of time helping Hydro with design improvements
- Eventually it became clear we should design our own system, rather than helping our competitor profit from our engineering expertise



What problems drove the design?

- 1. Clogged metering tips were an almost universal problem. Reps would have to go out and clean the tips, or get a service call after someone at the customer site poked the tip clean and the proportioner chemical usage spiked**
- 2. Broken chemical inlet fittings were another problem. Removing the chemical supply line to clean the tips tended to wear out and break the chemical inlet fitting**
- 3. Splashing from dirty air gap nozzle screens caused service calls**

What problems drove the design?

4. Clogged water inlet fittings took proportioners out of service, or resulted in a service call
5. Broken plastic covers generated service calls in food service accounts
6. Labels fell off units, confusing maids/kitchen workers trying to dispense the right chemical and making the installation look unprofessional
7. Ugly brass plumbing fittings were left exposed when several units were hooked together, and interconnecting units was time-consuming

These problems cost you money

Most reps in the field aren't sure how much a trouble call costs, but they know they lose chemical sales and sometimes even the customer when the proportioner isn't working.

How many days do accounts go with a proportioner out of service before it gets fixed? How much in the way of chemical sales is lost?

Our market research indicates that at any given time 1%-5% of accounts are experiencing proportioner problems.



How much money are you losing?

ISSA attendees we spoke with estimated the cost of a trouble call between \$40-\$120, or about \$80 based on direct costs, without factoring in the opportunity cost of not spending that time selling to new accounts.

Most reps do a couple service calls per week, which adds up to a cost of about \$8000 per year. On top of this, you're likely losing 1%-5% proportioner chemical sales due to having proportioners out of service, and also slowing your sales growth by having reps tied up in servicing instead of sales.

The following design innovations were designed to prevent these costs, so the dispenser would pay for itself.



Design Solution #1

Clogged metering tips were eliminated by switching to a system of controlling chemical dilution through a trough instead of an orifice. The trough is easily wiped clean, and there are four troughs per “metering peg” wheel for easy-to-adjust dilutions.

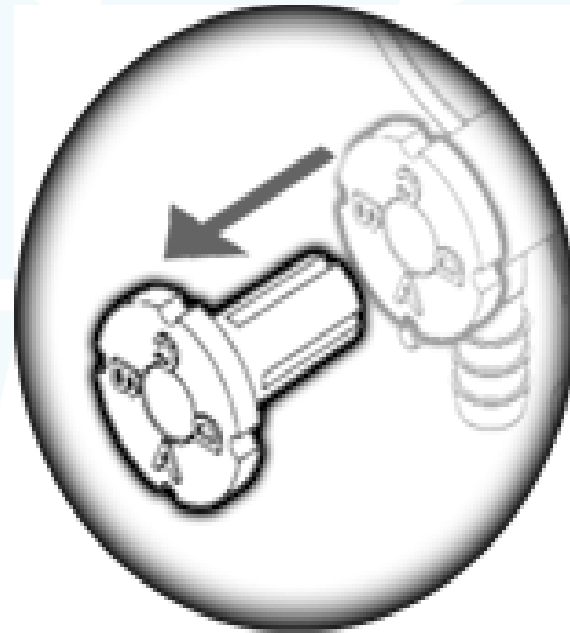

BETASTATIONMF06

Design Solution #2



- **Broken fitting:** the metering peg isn't in the chemical supply line. It can be removed from the venturi and wiped clean without disconnecting the chemical supply line, so the fittings aren't subjected to wrenching leverage and breakage
- **Chemically resistant materials** prevent brittleness

Design Solution #3

- Air gap nozzle splashing was eliminated by incorporating a fine mesh to keep particles out of the nozzle, and adding a lip to the nozzle design to wick away water and reduce calcium deposits
- R-Gaps are available for most areas, except Chicago and the West Coast where air gaps are required



*Competitor's venturi after 3 months
in hard water account*

Design Solution #4

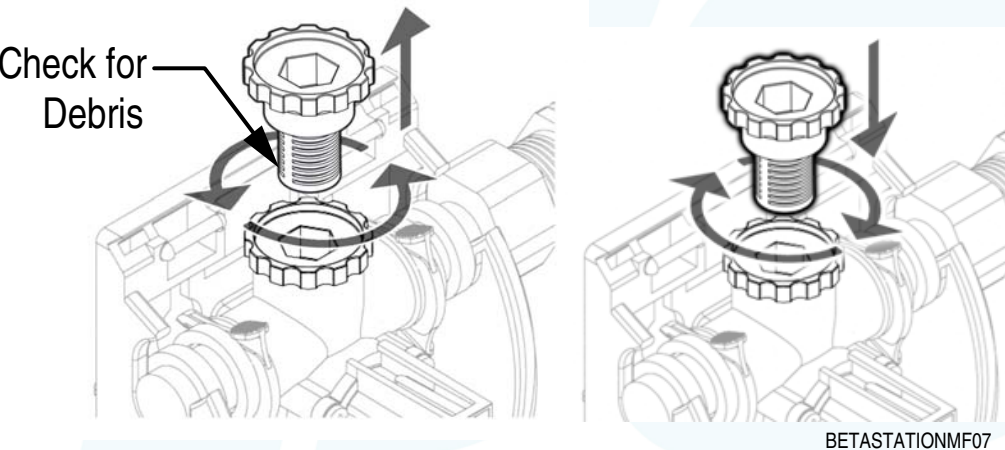

Water filter can be removed without disconnecting water supply, and has mesh sock that's easy to clean or replace

- To solve the issue of clogged water inlet screens, we increased the surface area from the standard 0.8" to 2"
- Water flows around the filter to downstream units, so the total filter surface area for three units is 6.0" instead of 0.8"
- One filter can clog, yet the other units downstream remain operational

Design Solution #5

- Plastic cover breakage was eliminated by eliminating buttons and using a dome shaped cover
- Whether the cover is pressed lightly or struck with terrible force, the unit turns on and excess force goes to the wall
- We set our 300 lb (150 kg) abuse-tester on BetaJet, and he couldn't break it

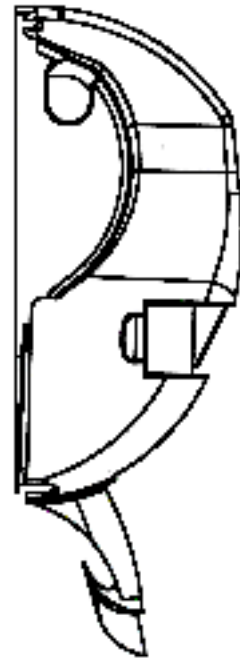

Nobody's broken a BetaJet cover yet!

Beta

Design Solution #6



Stocking graphics bands separately from dispensers reduces your inventory and makes field configuration easy!

- Rather than using labels, BetaJet has colored graphics bands with special tough printing right on them, so they look good in the field for years
- Custom printing available in single or multiple colors, on either white or colored plastic bands

The Beta logo is displayed in a bold, italicized, teal font.

Design Solution #7

- Interconnecting BetaJets is easy with tool-free quick assembly.
- Removing the blue clips lets you pull out water inlet and hole plug fittings and replace them with interconnects
- Units fit flush together for an attractive look



Beta

BetaJet pays dividends!

Increase private labeling capability with printed graphics bands	Better branding, more customer loyalty and less churn	Reduces customer turnover 1-5%
Reduce proportioner downtime	Less downtime increases chemical sales and customer satisfaction	Increases proportioner chemical sales 1-5%
Reduce trouble calls	Increased field rep morale and focus on generating more sales	Saves \$8,000 per rep per year













How to realize the benefits of BetaJet today

- The BetaJet *History* and *Foolproof* presentations provide everything you need to launch BetaJet and start saving money today:
 - Show benefits in terms of time and money so reps will want to use them
 - Explanation of installation, troubleshooting, and maintenance
 - Order forms on the following pages
- Simply copy and send out this CD to your field reps, or obtain copies from your Beta sales rep, and you'll start saving money and increasing customer satisfaction and chemical sales!













Graphics Bands

Custom Color Graphics Bands

Code #	Band	Print Color on Band Color
1205292	 Citrus Degreaser Citríco Desengrasador	White on Orange
1205299	 Odor Neutralizer Desodorante	White on Orange
1204663	 Pro Citrus AP Cleaner Limpiador Citríco	White on Orange
1204644	 Citrus Neutral Neutralizante Citríco	White on Orange
1205288	 All-Purpose Cleaner Limpiador en General	White on Purple
1204664	 Carpet Extraction Cleaner Limpiador de Alfombras	White on Purple
1204832	 Disinfectant Cleaner Limpiador de Desinfectante	White on Purple
1205290	 Bio Waste Degradar Removedor de Desecho	Blue on White
1205297	 Floor Finish Restorer Recondicionador de Pisos	Orange on White
1204665	 Floor Cleaner Limpiador de Piso	Black on White
1204674	 Pot & Pan Detergent Limpiador de Ollas y Tazas	Black on White











Custom Color Graphics Bands

Code #	Band	Print Color on Band Color
1204799	 Quat Surface Sanitizer Sanitizante Superficie Quat	Black on White
1204640	 Pot & Pan Sanitizer Sanitizante Ollas y Tazas	Black on White
1204648	 Quat Sanitizer Sanitizante Quat	Black on White
1205289	 Bathroom Cleaner Limpiador de Baños	White on Red
1205293	 Degreaser Desengrasador	White on Red
1204667	 Germicidal Cleaner Limpiador microbios	White on Red
1204668	 Oven and Grill Limpiador para Hornos y Parrillas	White on Red
1204583	 Floor Cleaner Limpiador de Piso	White on Red
1205295	 Flatware Presoak Remojador de Cubiertos	Black on Yellow
1205296	 Floor Cleaner Limpiador de Pisos	Black on Yellow
1204666	 Pine Oil Cleaner Limpiador de Aceite de Pino	Black on Yellow







Graphics Bands - Continued

Custom Color Graphics Bands

Code #	Band	Print Color on Band Color
1204643	 Air Freshener Aromatizante	Black on Yellow
1205298	 Glass Cleaner Limpiador de Vidrios	White on Blue
1205300	 Pot & Pan Detergent Jabon de Ollas y Sartenes	White on Blue
1204675	 Flatware PreSoak Prelavado	White on Blue
1204641	 Glass Cleaner Limpiador de Vidrio	White on Blue
1205294	 Disinfectant Cleaner Desinfectante Limpiador	White on Green
1205301	 Sanitizer Desinfectante	White on Green
1204662	 Bathroom Cleaner Limpiador Para Baños	White on Green
1204669	 Degreaser Cleaner Limpiador Desengrasante	White on Green
1204670	 Degreaser Cleaner Limpiador Desengrasante	White on Green
1204642	 Pot & Pan Detergent Detergente Para Sartenes	White on Green

Custom Color Graphics Bands

Code #	Band	Print Color on Band Color
1204647	 All Purpose Cleaner Limpiador Para Todo	White on Green
1205291	 Carpet Cleaner Limpiador de Carpeta	White on Teal
1204671	 Disinfectant Cleaner Limpiador de Desinfectante	White on Teal
1204646	 Tub and Tile Cleaner Limpiador Para Tinas y Azulejo	White on Teal
1204582	 PreSoak Prelavado	White on Teal

A History of BetaJet



Beta